

SECTION A-A

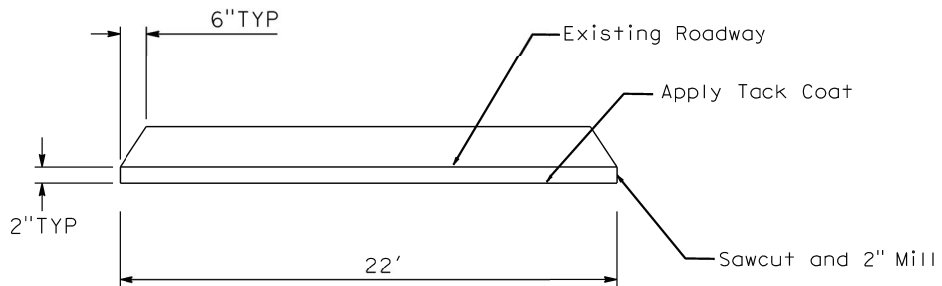

SECTION B-B

NOTE:

1- Tack coat shall be applied to all horizontal and vertical surfaces.

COUNTY OF RIVERSIDE TRANSPORTATION DEPARTMENT
SPEED BUMP

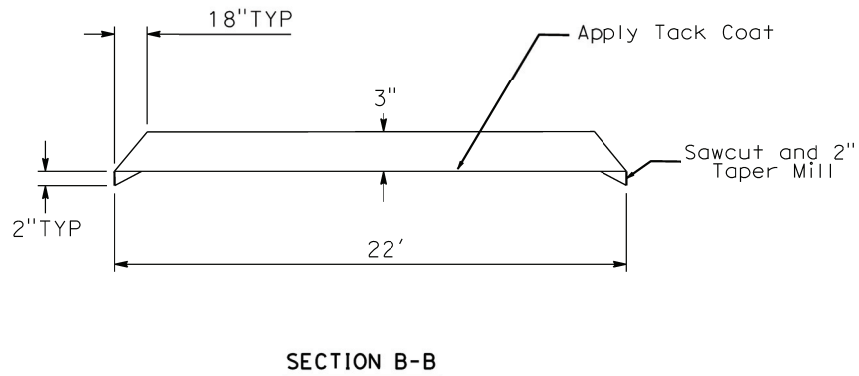
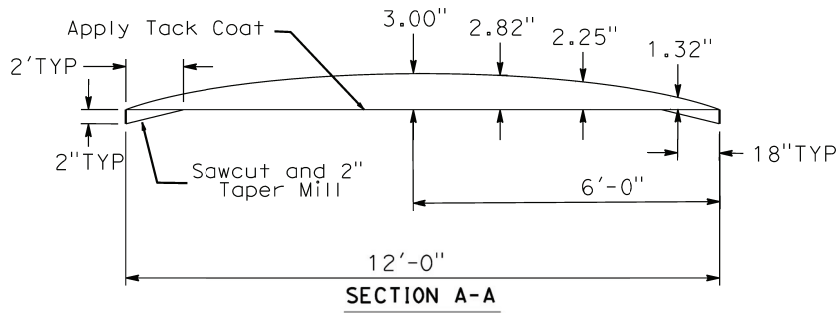
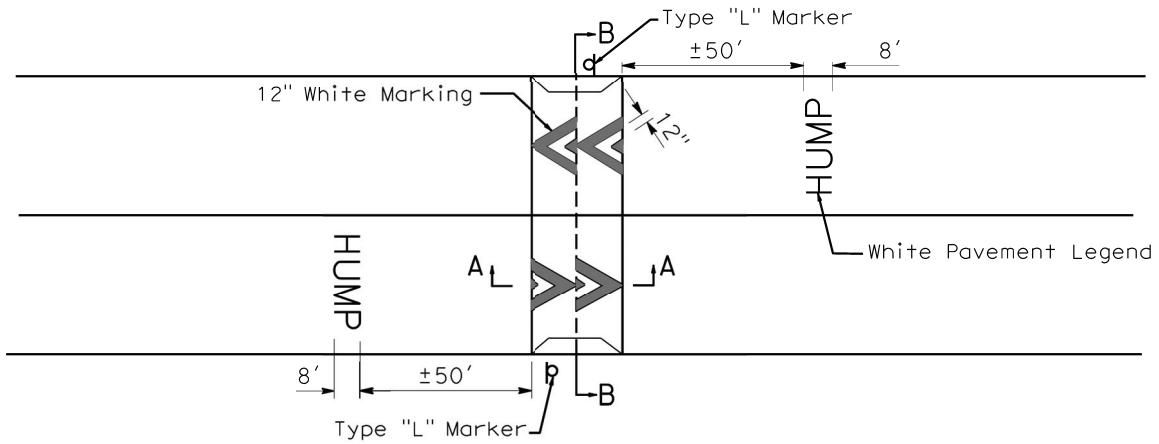

NOTES:

1. A "Speed Hump" (W17-1) shall be placed at 250' to the hump location. Signs shall be of high intensity sheeting (30"x30"). Co-mount a W13-1 "25 MPH" (24"x24") warning sign per CALTRANS standards.
- 2- Tack coat shall be applied to all horizontal and vertical surfaces.

COUNTY OF RIVERSIDE
TRANSPORTATION DEPARTMENT

SPEED HUMP