

**LEGEND:**



**ABBREVIATIONS:**

TE TAPERED EDGE

**CASE A**  
TAPERED EDGE

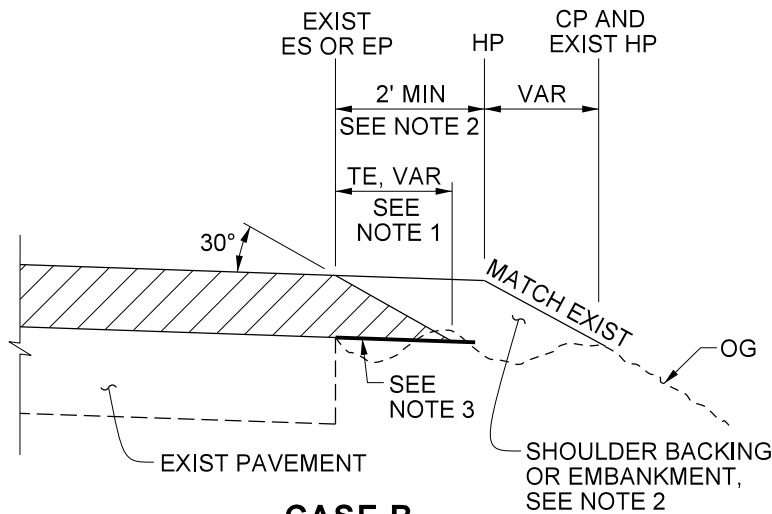

**CASE B**  
TAPERED EDGE

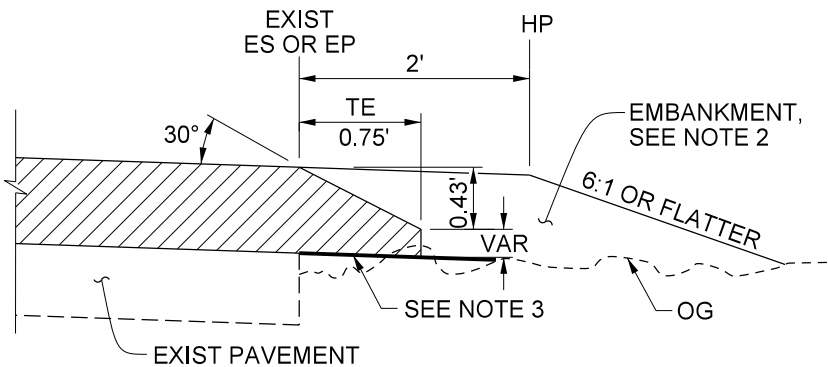

**DETAIL "A"**

FOR HMA OVERLAY THICKNESS MORE THAN 0.43'.

**NOTES:**

1. DETAILS SHOWN FOR HMA OVERLAY THICKNESS LESS THAN 0.43'. SEE DETAIL "A" FOR HMA OVERLAY THICKNESS MORE THAN 0.43' OR CONCRETE OVERLAY.
2. FOR LOCATIONS AND LIMITS OF SHOULDER BACKING OR EMBANKMENT SEE PROJECT PLANS.
3. GRADE EXISTING GROUND TO PLACE TAPERED EDGE. 1' MINIMUM WIDTH.

NOT TO SCALE

PREPARED UNDER THE SUPERVISION OF:

*Mark Lancaster*

11/30/22  
DATE

DIRECTOR OF TRANSPORTATION  
MARK LANCASTER, P.E.

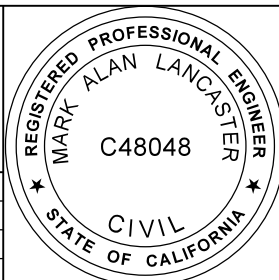

COUNTY OF RIVERSIDE

**SAFETY EDGE**

**STANDARD No. 214 (1 OF 2)**

REVISION	DESCRIPTION	MARK	DATE	APPROVED

**LEGEND:**

 HMA OVERLAY

**ABBREVIATIONS:**

TE TAPERED EDGE  
 HW HINGE WIDTH, DISTANCE FROM EP TO HP

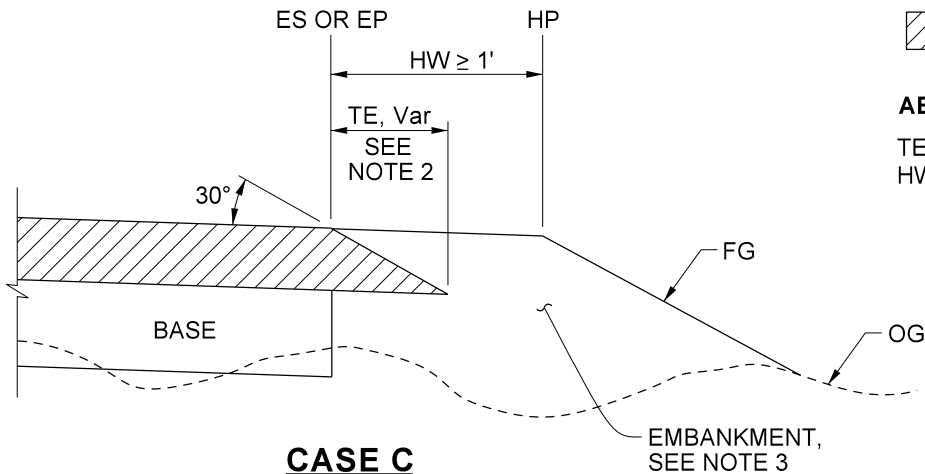

**CASE C**  
 TAPERED EDGE - FILL SECTION, HW ≥ 1'

**FILL SECTION**

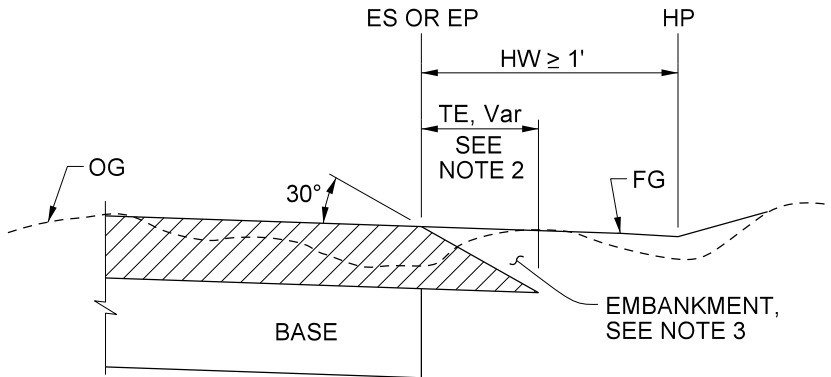

**CASE D**  
 TAPERED EDGE - FILL SECTION, HW ≥ 1'

**CUT SECTION**

**NOTES:**

1. DETAILS SHOWN FOR HMA OVERLAY THICKNESS LESS THAN 0.43'. SEE DETAIL "A" FOR HMA OVERLAY THICKNESS MORE THAN 0.43' OR CONCRETE OVERLAY.
2. FOR LOCATIONS AND LIMITS OF SHOULDER BACKING OR EMBANKMENT SEE PROJECT PLANS.

NOT TO SCALE

PREPARED UNDER THE SUPERVISION OF:

*Mark Lancaster*

11/30/22  
 DATE

DIRECTOR OF TRANSPORTATION  
 MARK LANCASTER, P.E.

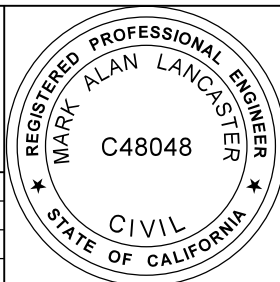

COUNTY OF RIVERSIDE

**SAFETY EDGE**

**STANDARD No. 214 (2 of 2)**

REVISION	DESCRIPTION	MARK	DATE	APPROVED