

RIVET LOCATIONS
SEE NOTE 6 ON
SHEET 2 OF 2

DIRECTION OF
TRAFFIC FLOW

STREET SIDE
OF POST

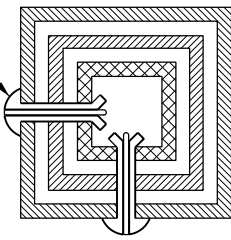

SECTION "A-A"

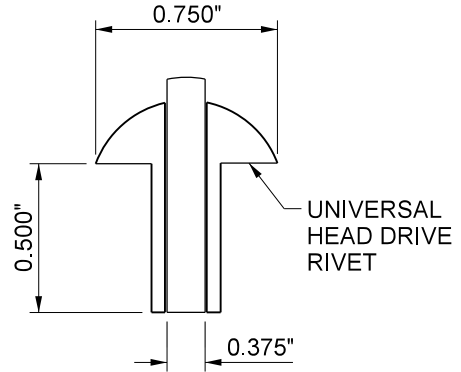

RIVET DETAIL

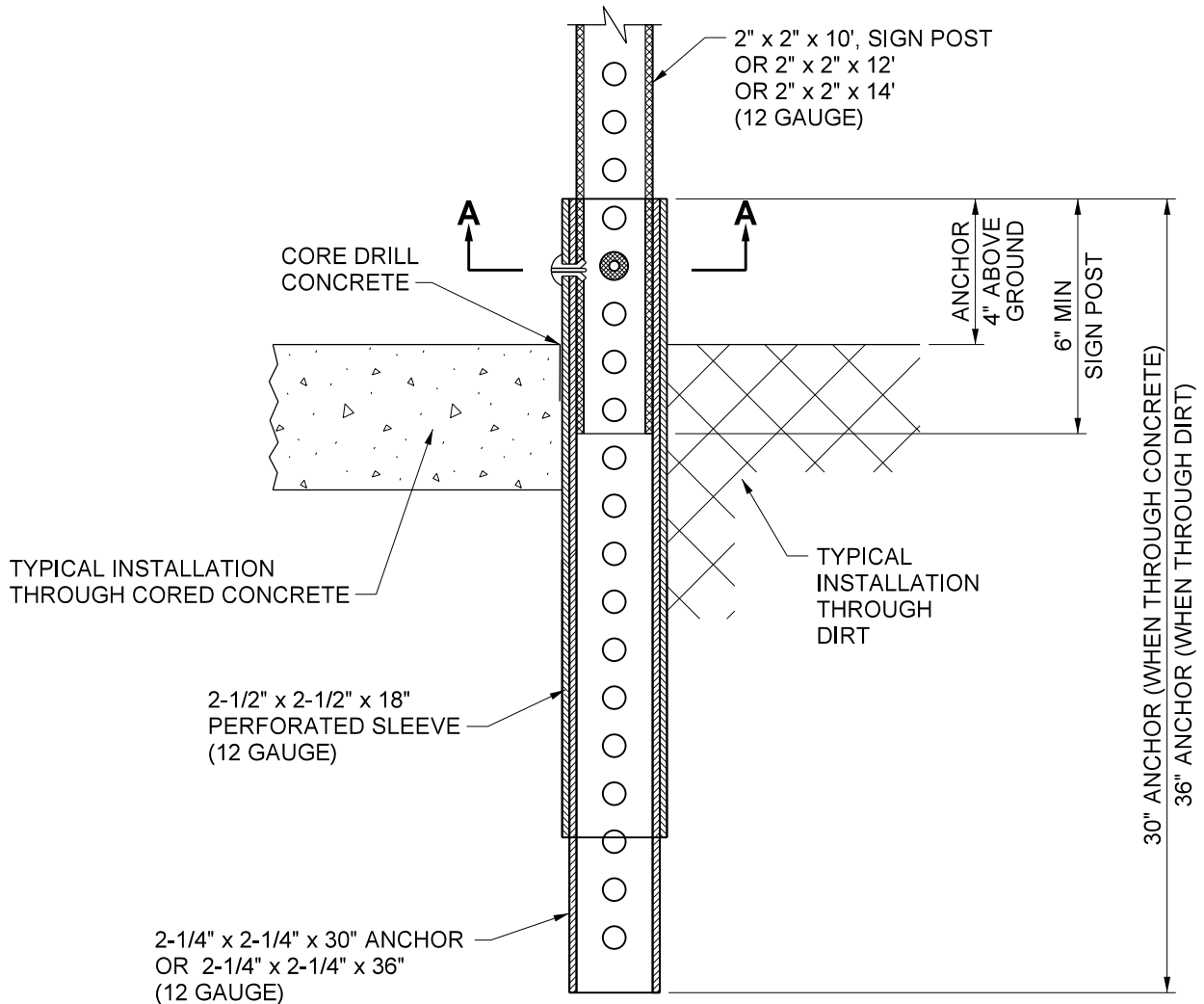

NOT TO SCALE

PREPARED UNDER THE SUPERVISION OF:

Mark Lancaster

11/30/22
DATE

DIRECTOR OF TRANSPORTATION
MARK LANCASTER, P.E.



COUNTY OF RIVERSIDE

**SIGN POST
INSTALLATION**

STANDARD No. 1222 (1 OF 2)

REVISION	DESCRIPTION	MARK	DATE	APPROVED

NOTES:

1. SQUARE PERFORATED STEEL TUBE POST WITH TWO PIECE ANCHOR AND SLEEVE, "TELESPAR", SHALL BE USED FOR ALL TRAFFIC CONTROL AND INFORMATIONAL SIGNS WITHIN ROAD RIGHT OF WAY.
2. THE NUMBER OF POSTS REQUIRED FOR SIGN INSTALLATION SHALL BE DETERMINED BY THE AREA OF THE SIGN OR COMBINATION OF SIGNS TO BE INSTALLED. A SINGLE POST SHALL BE USED WHERE BOTH THE LENGTH AND WIDTH ARE 48" OR LESS. DOUBLE POSTS SHALL BE USED WHERE EITHER THE LENGTH OR WIDTH EXCEEDS 48".
3. THE 2 PIECE ANCHOR AND SLEEVE ASSEMBLY SHALL CONSIST OF A 2 1/4" SQUARE BY 30" (THROUGH SIDEWALK) OR 36" (THROUGH SOIL) ANCHOR WITH A 2 1/2" SQUARE BY 18" SLEEVE. ALL SLEEVES AND ANCHORS SHALL BE 12 GAUGE.
4. THE ANCHOR AND SLEEVE ASSEMBLIES SHALL BE DRIVEN SIMULTANEOUSLY UNTIL ONLY 4" REMAINS ABOVE GROUND LEVEL.
5. ALL DIRT SHALL BE REMOVED FROM THE INSIDE TOP 6" MINIMUM OF THE ANCHOR ASSEMBLY TO ALLOW FOR THE INSTALLATION OF THE SIGN POST.
6. INSTALL 2" SQUARE SIGN POST MINIMUM 6" INTO THE ANCHOR ASSEMBLY AND SECURE IN PLACE WITH TWO 3/8" DRIVE RIVETS AS SHOWN. THE RIVETS SHALL BE INSTALLED ON THE SIDE FACING TRAFFIC FLOW AND THE SIDE OF APPROACHING TRAFFIC AS SHOWN IN ORDER TO ACHIEVE THE MAXIMUM BREAK-AWAY EFFECT.
7. INSTALLATION ACCORDING TO THESE REQUIREMENTS IS ESSENTIAL TO MAINTAIN BREAKAWAY CHARACTERISTICS OF THE POST SYSTEM.
8. SEE STANDARD No's. 1220 AND 1221 FOR PLACEMENT OF SIGN POST.
9. ALL ANCHOR ASSEMBLIES SHALL BE CORE DRILLED THROUGH CONCRETE AND ASPHALT.
10. ALL SIGNS ATTACHED TO PERFORATED POSTS SHALL HAVE ZINC COATED OR STAINLESS STEEL WASHERS BEHIND THE RIVET THAT ARE LARGER THAN THE HEAD OF THE RIVET.
11. ALL REGULATORY, WARNING AND GUIDE SIGNS INSTALLED SHALL BE 0.080 INCHES IN THICKNESS.
12. ALL SIGNS 36" OR LARGER SHALL BE INSTALLED WITH BACK BRACES SPECIFICALLY DESIGNED FOR 2" SQUARE PERFORATED POSTS. (2" RISE)
13. IN SOME INSTANCES CONCRETE FOUNDATION MAY BE REQUIRED TO ENSURE PROPER STABILITY, THIS OPTION IS TO BE USED AT THE DISCRETION OF THE COUNTY ENGINEER OR DESIGNEE.

NOT TO SCALE

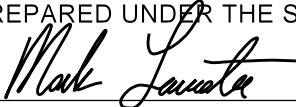
PREPARED UNDER THE SUPERVISION OF:			
			11/30/22
DIRECTOR OF TRANSPORTATION MARK LANCASTER, P.E.			DATE
REVISION	DESCRIPTION	MARK	APPROVED



COUNTY OF RIVERSIDE
SIGN POST INSTALLATION
STANDARD No. 1222 (2 OF 2)